

# Wagenheber Aluminium-Car Jack Cric

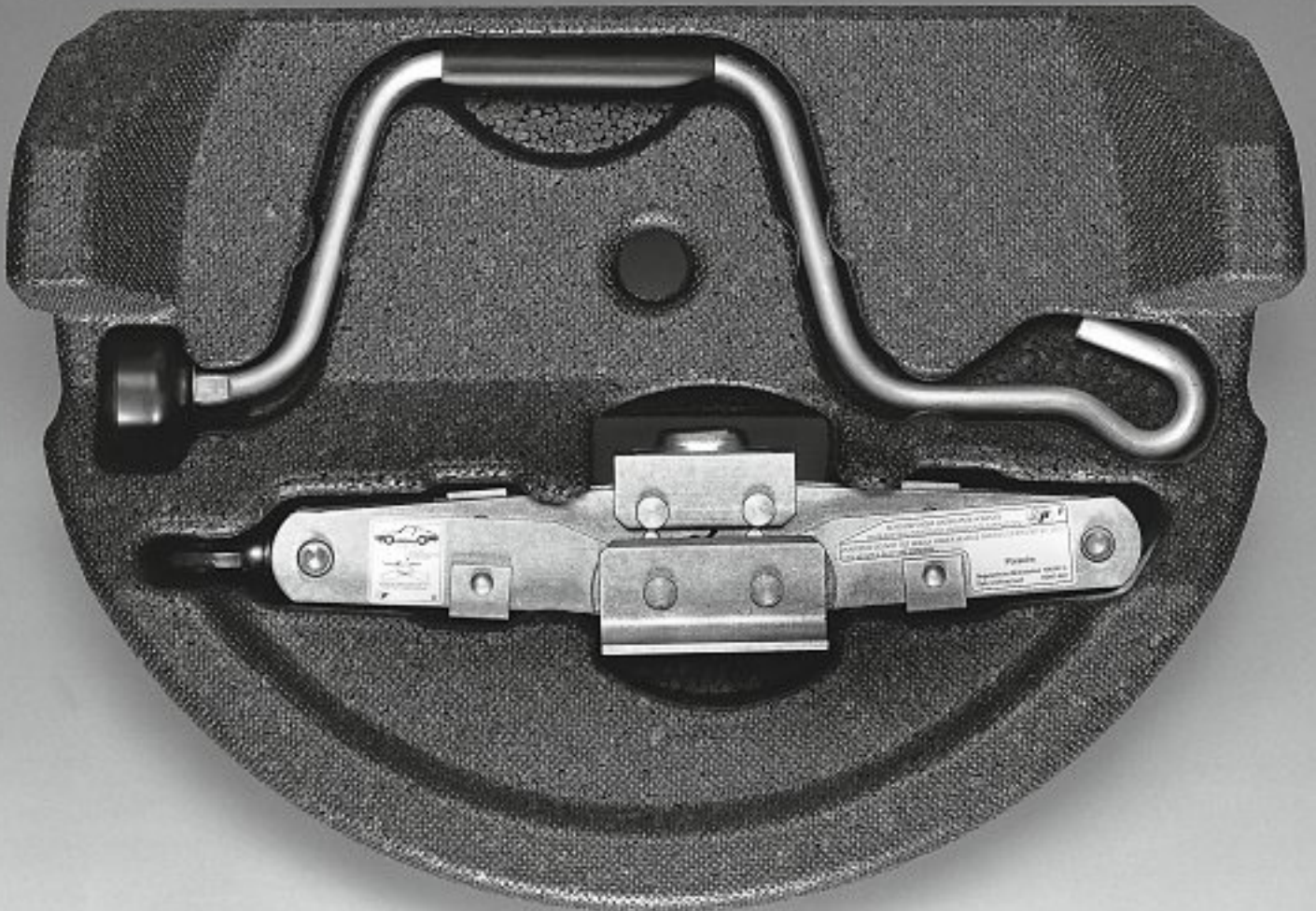

Scherenheber mit bogenförmiger Hebekurve und gehärteter Alu-Kurbel.  
Pantograph jack with arc-shaped lift curve and hardened alu crank.  
Cric avec arc courbé de levage et manivelle en alu trempé.



Porsche »Boxster«  
Schaumteil für Reserverad mit Scherenheber und Kurbel.  
Foam material for spare wheel with jack and crank.  
Élément en mousse pour roue de rechange avec cric et manivelle.



1996  
Konstruktionsänderungen vorbehalten.  
Subject to design changes.  
Sous réserve de modifications de construction.

Allendorfer Fabrik  
**ING. HERBERT PANNE GMBH**  
D-35753 GREIFENSTEIN-ALLENDORF, LAHN-DILL-KREIS  
Telefon (0 64 78) 8 09-0 · Telefax (0 64 78) 12 05



# Aluminium-Scherenwagenheber pantograph jack · cric

$H_{min.}$ ,  $H_{max.}$  und Kopfausführung nach Wunsch,  
bogenförmige Hebekurve (E) der Fahrzeugbewegung angepaßt.

$H_{min.}$ ,  $H_{max.}$  and jack head as desired,  
arc-shaped lift curve (E) adapted to the movement of the vehicle.

$H_{min.}$ ,  $H_{max.}$  et tête de construction selon besoin,  
arc courbé de levage (E) adapté au mouvement du véhicule.

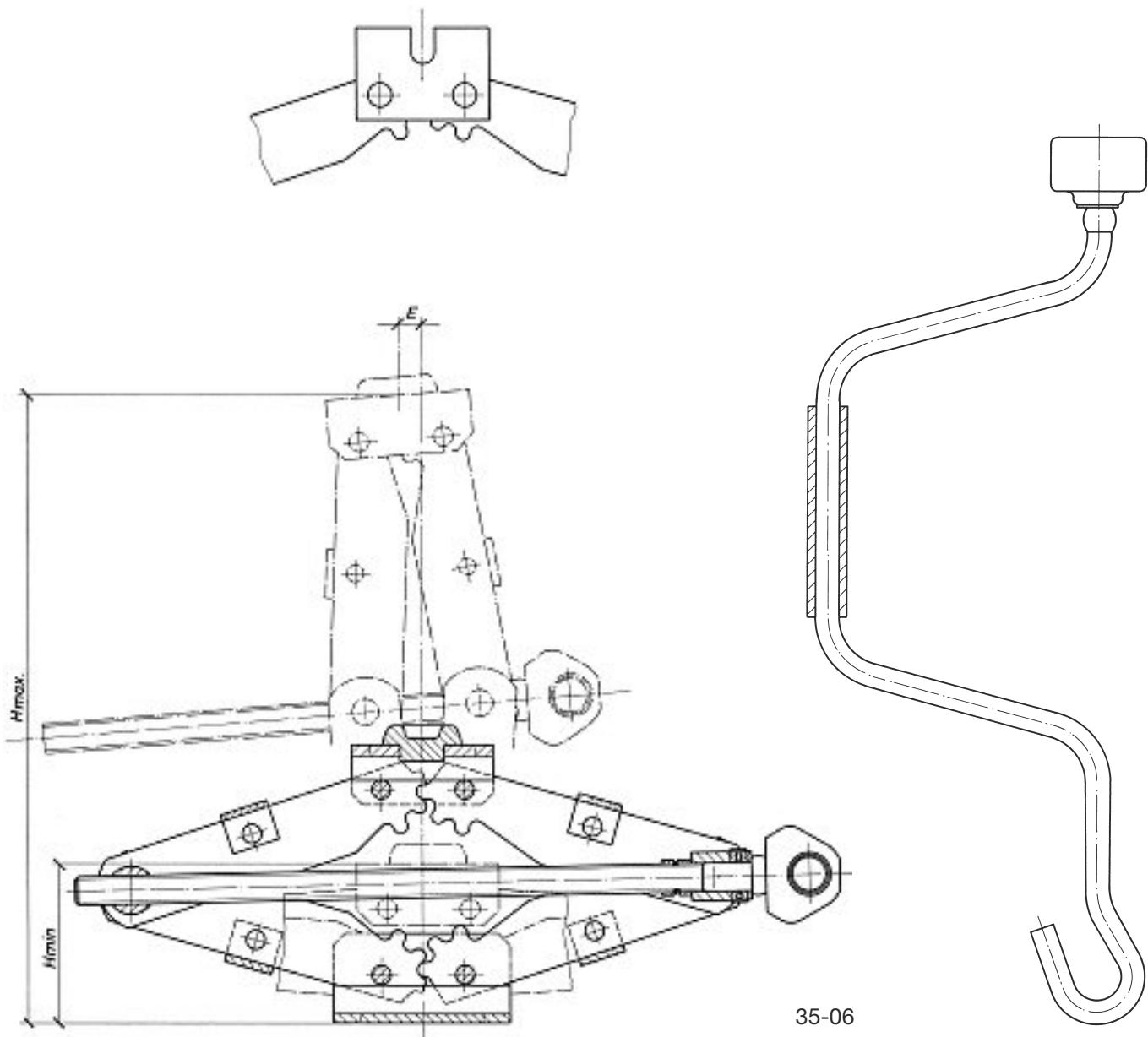

35-06  
DBP

Tragkraft/capacity/force 10.000 N 1000 kg

Eigengewicht/dead-weight/poids 1,2 kg



# Aluminium-Gelenkwagenheber swivel jack · cric articulé

H<sub>min.</sub>, H<sub>max.</sub> und Kopfausführung nach Wunsch, z. B. »A« oder »B«

H<sub>min.</sub>, H<sub>max.</sub> as desired, jack head f. i. »A« or »B«

H<sub>min.</sub>, H<sub>max.</sub> selon besoin, tête de construction p. e. »A« ou »B«

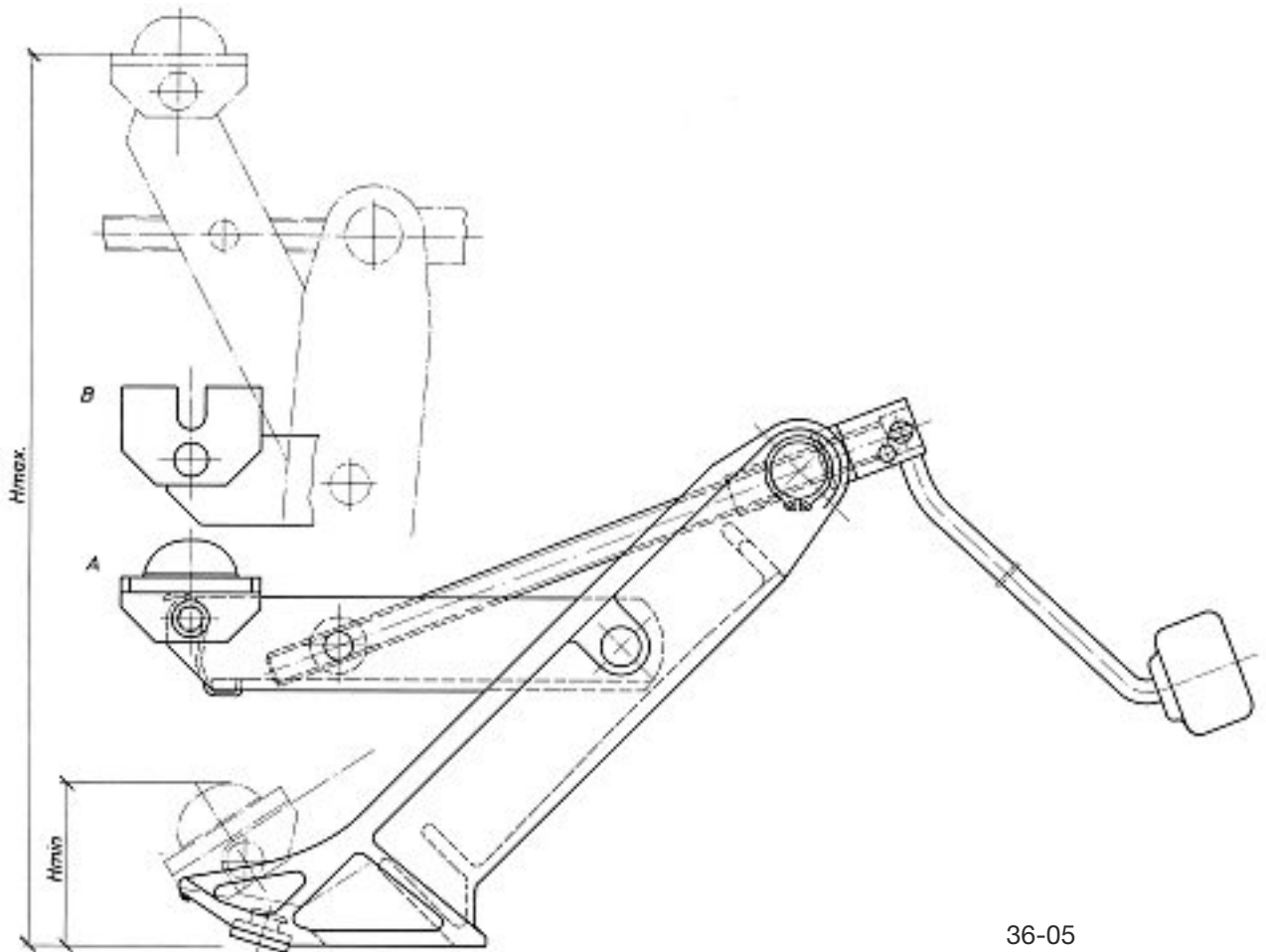

36-05

Tragkraft/capacity/force 10.000 N 1000 kg

Eigengewicht/dead-weight/poids 0,98 kg



# Stahl-Wagenheber Steel-car-jacks · crics en acier

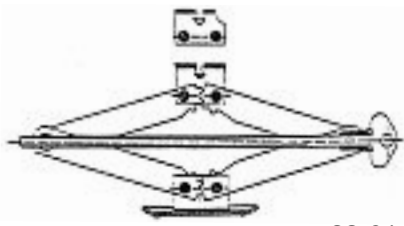

33-01



33 B

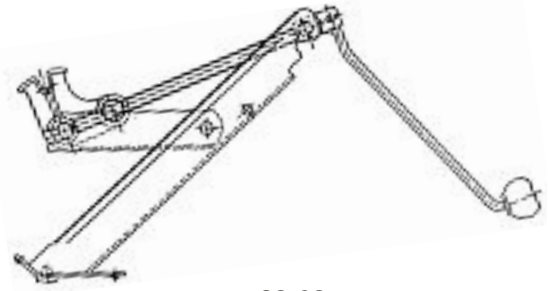

23-03



20-03

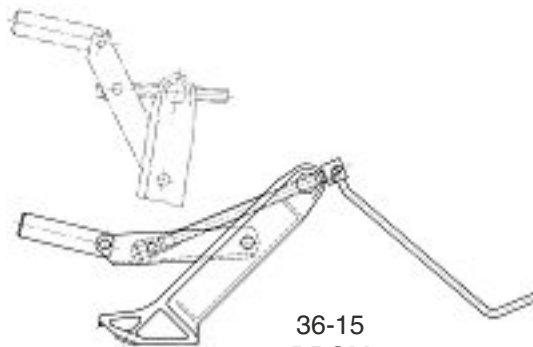

36-15  
DBGM

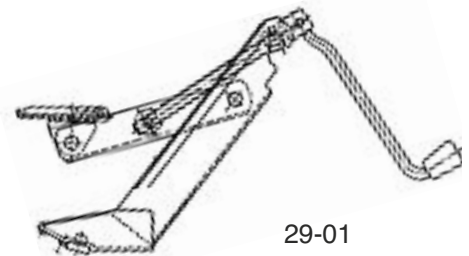

29-01



19-02

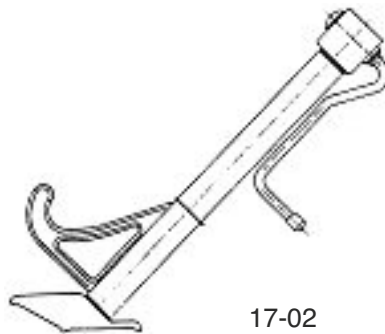

17-02



16-05

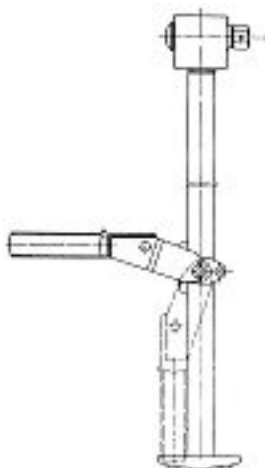

12-06

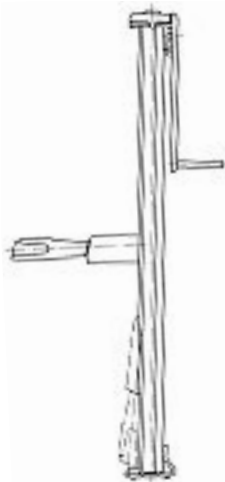

12-09

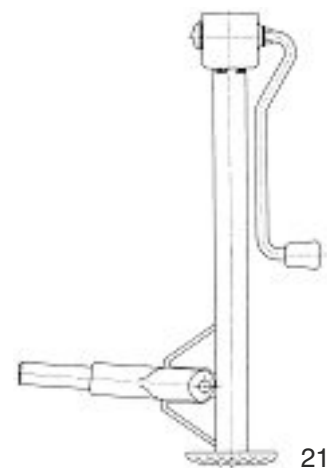

21-01